

# PCM1794 & DIX9211 Audio DAC

by Konrad Siemientkowski

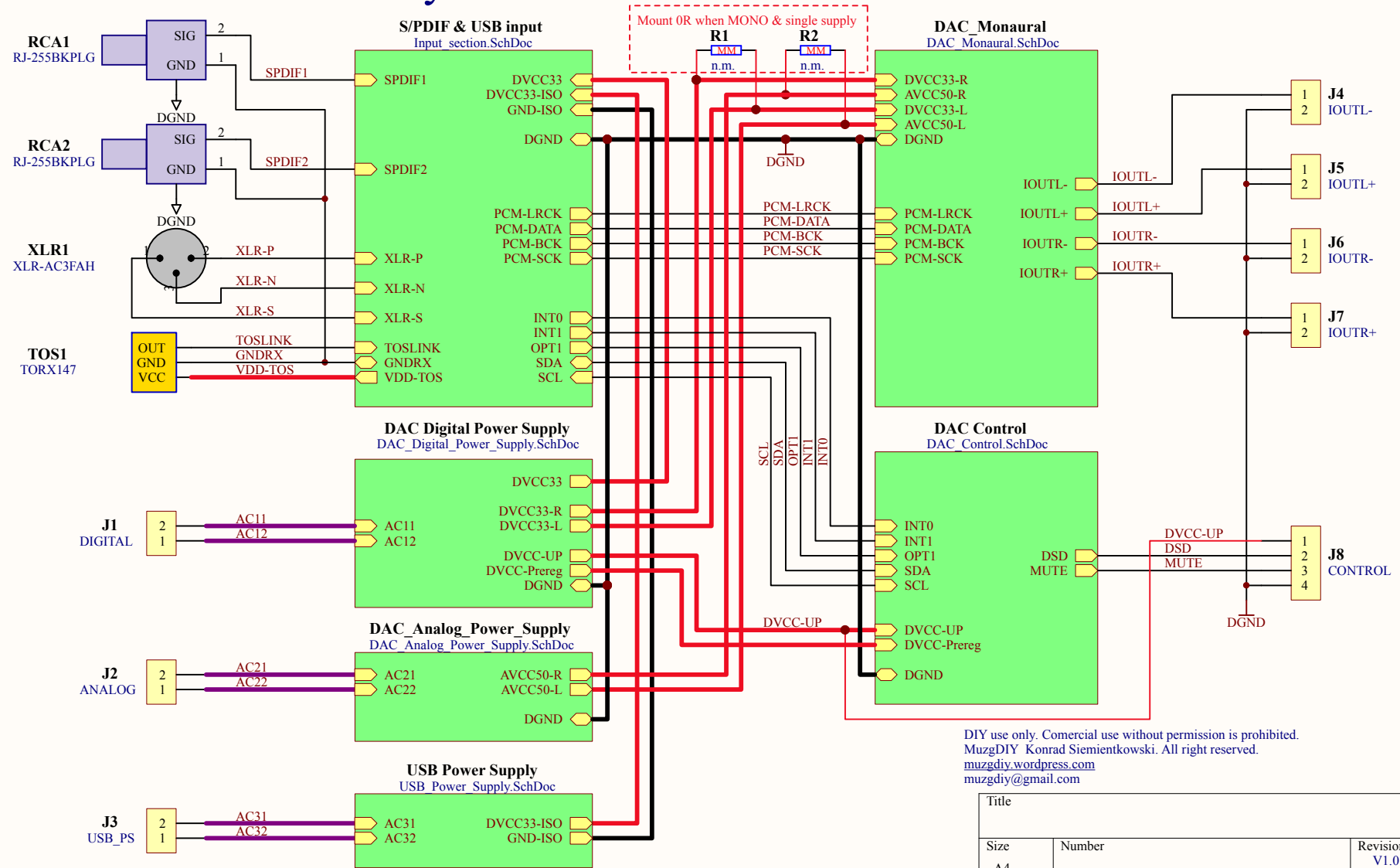

DIY use only. Commercial use without permission is prohibited.  
 MuzgDIY Konrad Siemientkowski. All right reserved.  
[muzgdiy.wordpress.com](http://muzgdiy.wordpress.com)  
[muzgdiy@gmail.com](mailto:muzgdiy@gmail.com)

Title		
Size	Number	Revision
A4		V1.0 09.09.2018
Date:	2018-09-09	Sheet of
File:	D:\Projekty Altium\...\DAC Main.SchDoc Drawn By:	

# S/PDIF & USB input for PCM1794 DAC

by Konrad Siemientkowski

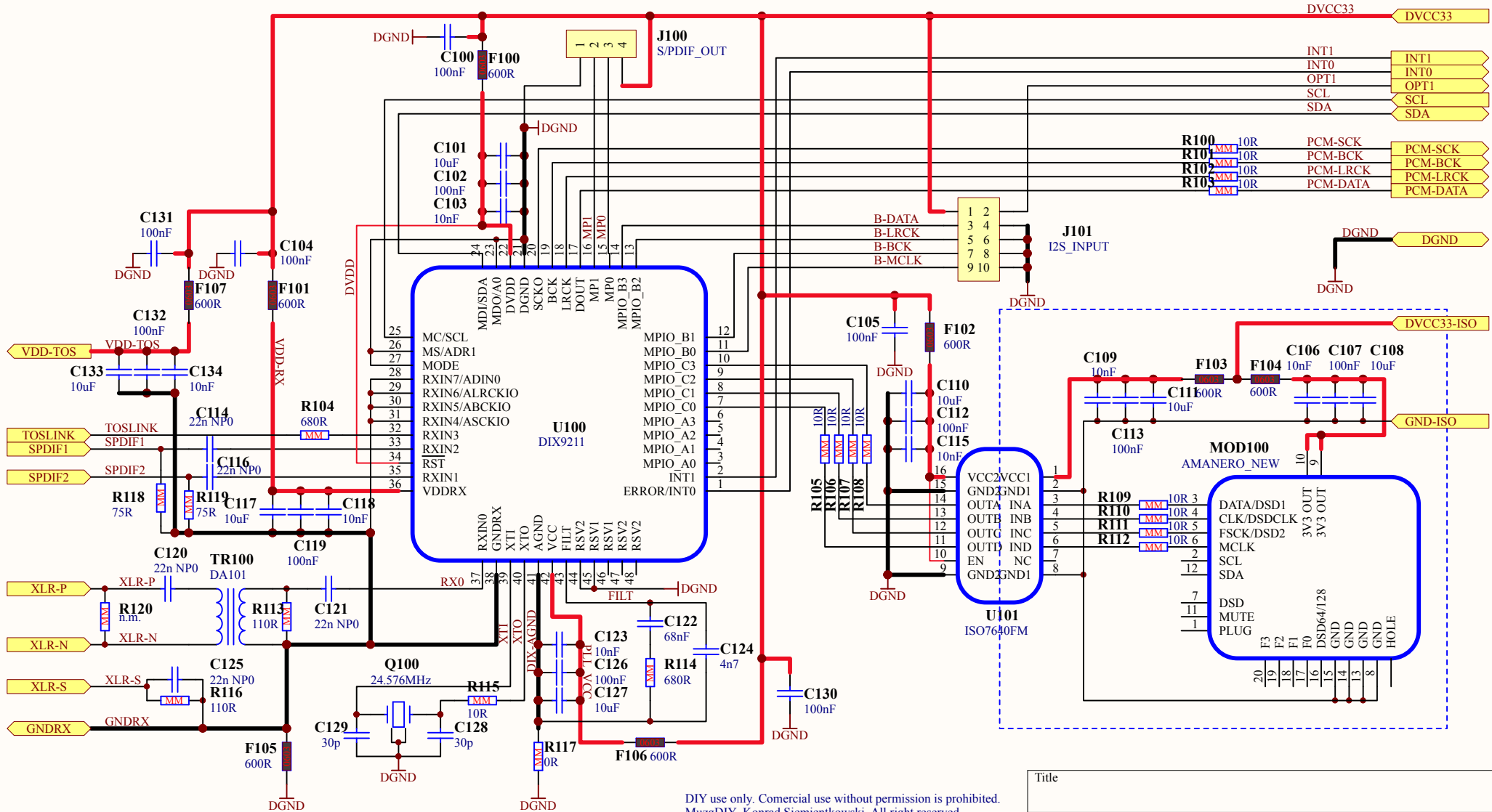

DIY use only. Commercial use without permission is prohibited.  
 MuzgDIY Konrad Siemientkowski. All right reserved.  
[muzgdiy.wordpress.com](http://muzgdiy.wordpress.com)  
[muzgdiy@gmail.com](mailto:muzgdiy@gmail.com)

Title		
Size	Number	Revision
A4		V1.0 09.09.2018
Date:	2018-09-09	Sheet of
File:	D:\Projekty Altium\...\Input section.SchDoc Drawn By:	

# Monaural DAC stage with PCM1794A

by Konrad Siemientkowski

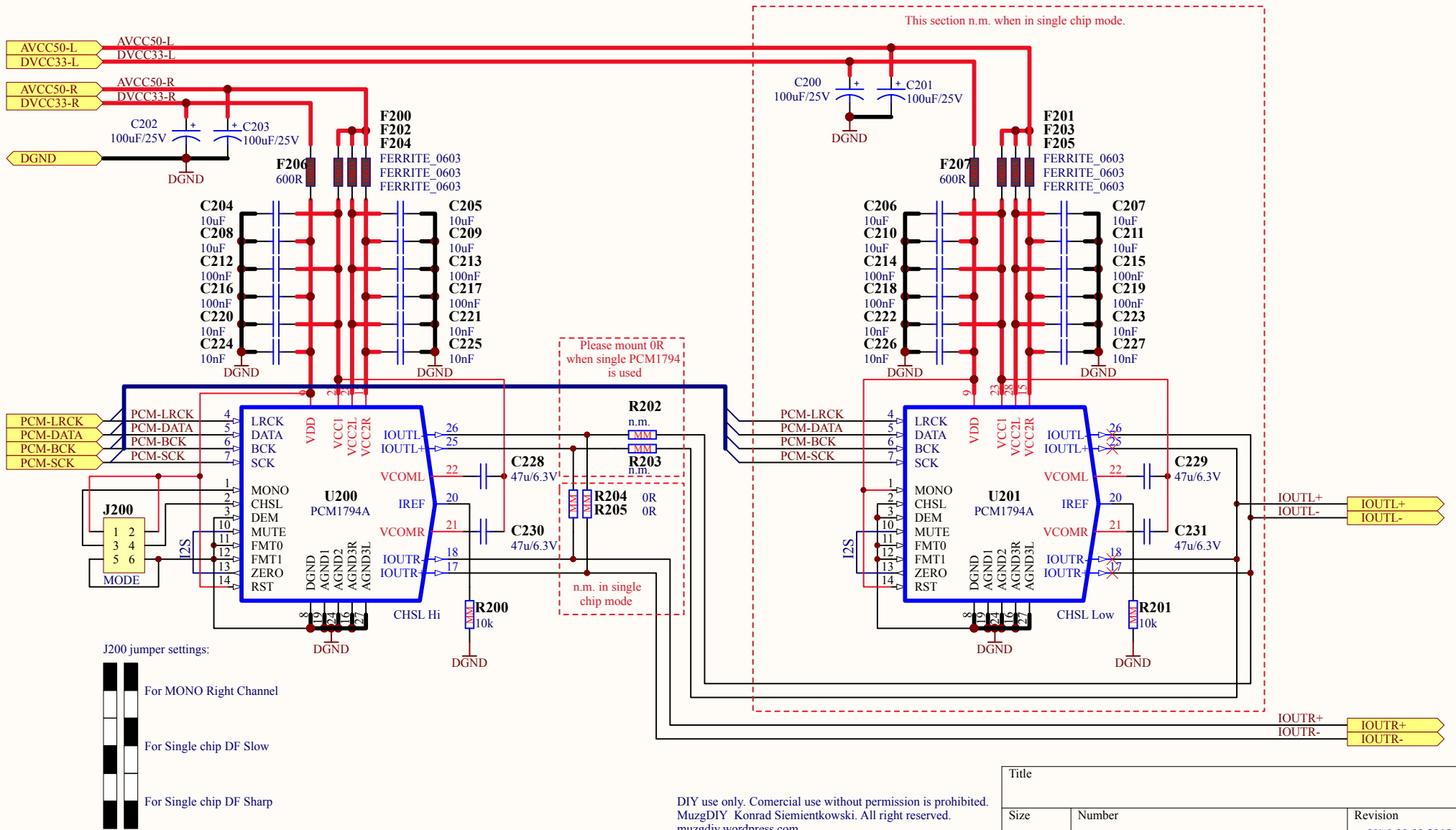

DIY use only. Commercial use without permission is prohibited.  
 MuzgDIY Konrad Siemientkowski. All right reserved.  
[muzgdiy.wordpress.com](http://muzgdiy.wordpress.com)  
[muzgdiy@gmail.com](mailto:muzgdiy@gmail.com)

Title		
Size	Number	Revision
A4		V1.0 09.09.2018
Date:	2018-09-09	Sheet of
File:	D:\Projekty Altium\..DAC Monaural.Sch	Drawn By:



# Digital Power Supply for PCM1794 DAC

by Konrad Siemientkowski

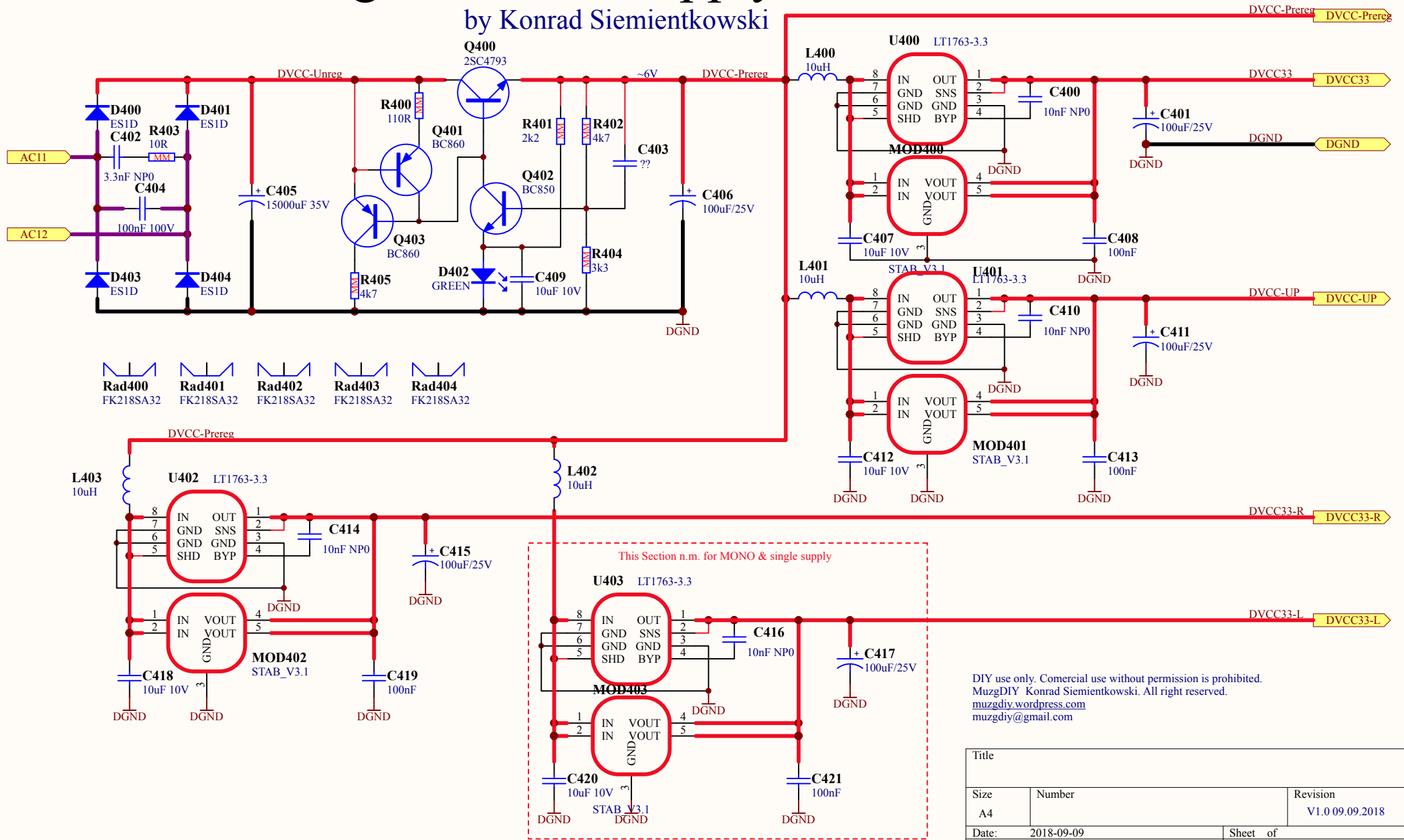

- Rad400** FK218SA32
- Rad401** FK218SA32
- Rad402** FK218SA32
- Rad403** FK218SA32
- Rad404** FK218SA32

DIY use only. Commercial use without permission is prohibited.  
 MuzgDIY Konrad Siemientkowski. All right reserved.  
[muzgdiy.wordpress.com](http://muzgdiy.wordpress.com)  
[muzgdiy@gmail.com](mailto:muzgdiy@gmail.com)

Title		
Size	Number	Revision
A4		V1.0 09.09.2018
Date:	2018-09-09	Sheet of
File:	D:\Projekty Altium\..DAC Digital Power Supply\SchDoc	

# Analog Power Supply for PCM1794 DAC

by Konrad Siemientkowski

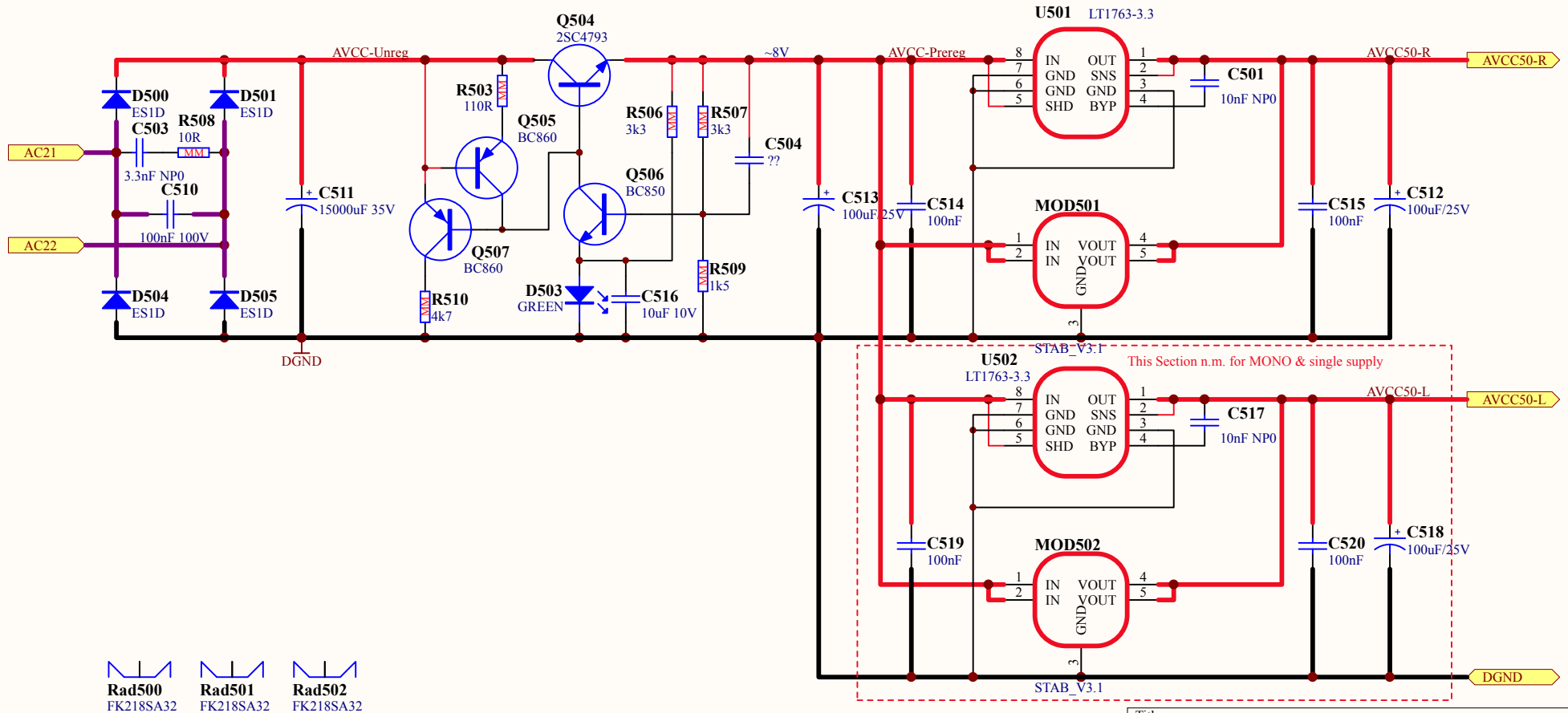

Rad500 FK218SA32  
 Rad501 FK218SA32  
 Rad502 FK218SA32

DIY use only. Comercial use without permission is prohibited.  
 MuzgDIY Konrad Siemientkowski. All right reserved.  
[muzgdiy.wordpress.com](http://muzgdiy.wordpress.com)  
[muzgdiy@gmail.com](mailto:muzgdiy@gmail.com)

Title		
Size	Number	Revision
A4		V1.0 09.09.2018
Date:	2018-09-09	Sheet of
File:	D:\Projekty Altium\..DAC Analog Power Supply	BySchDoc

# USB Power Supply for PCM1794 DAC

by Konrad Siemientkowski

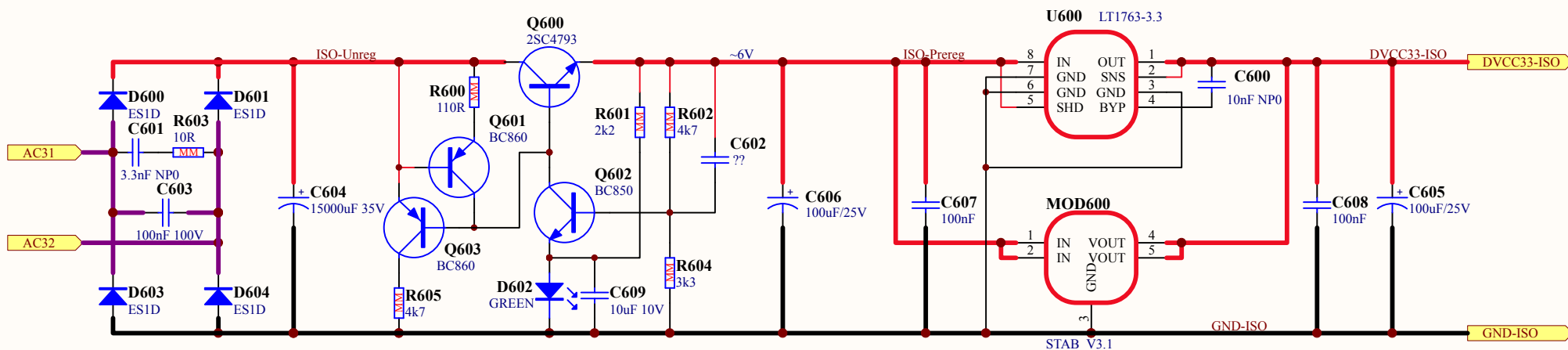

DIY use only. Commercial use without permission is prohibited.  
 MuzgDIY Konrad Siemientkowski. All right reserved.  
[muzgdiy.wordpress.com](http://muzgdiy.wordpress.com)  
[muzgdiy@gmail.com](mailto:muzgdiy@gmail.com)

Title		
Size	Number	Revision
A4		V1.0 09.09.2018
Date:	2018-09-09	Sheet of
File:	D:\Projekty Altium\...USB Power Supply\USB.Dwg	